

# Operating instructions

Pipe Cutting and  
Beveling Machine

**RA 41 Plus (H)**

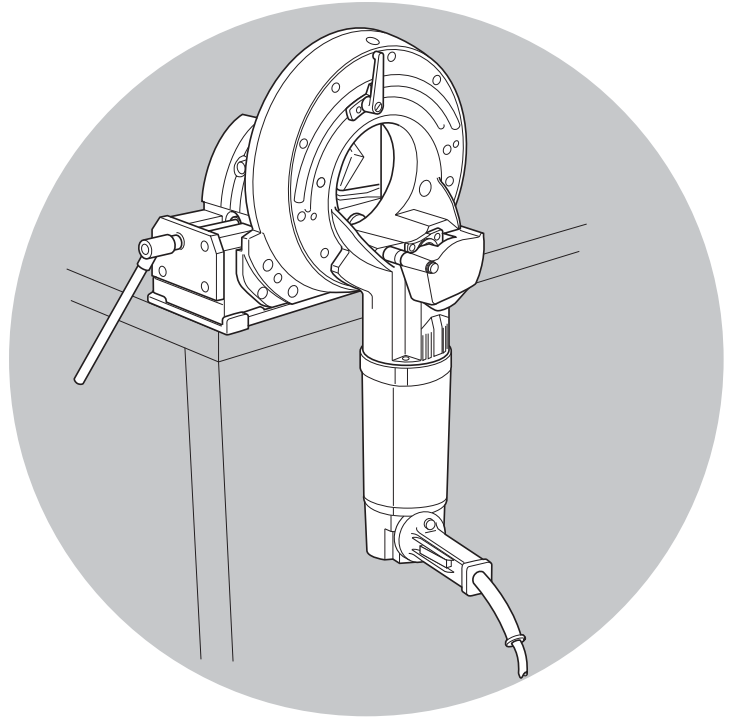

Code 790 046 773

Translation of original operating instructions

| Machine-no.:

---

All rights reserved, in particular the rights of duplication and distribution as well as translation.  
Duplication and reproduction in any form (print, photocopy, microfilm or electronic) require the written permission of Orbitalum Tools GmbH.

# Table of contents

	Page
0 About these instructions	1
0.1 Warning messages	1
0.2 Further symbols and displays	2
0.3 Abbreviations	2
1 Notes on safety	3
1.1 Proper use	3
1.2 Safety regulations	3
1.3 Working with safety in mind	4
1.4 Waste disposal / environmental protection	5
1.5 Further safety regulations	5
2 Design of the product	6
2.1 Standard	6
2.2 Accessories	7
3 Features and scope of application	8
3.1 Features	8
3.2 Scope of application	9
4 Technical specifications	10
4.1 Rating	10
5 Commissioning	11
5.1 Scope of delivery*	11
6 Transport and assembly	12
6.1 Fitting the quick-mounting plate	12
6.2 Transporting and fitting the pipe cutter	13
7 Operation	14
7.1 Setting the saw position 1	15
7.1.1 Preparatory work	15
7.1.2 Fitting the saw blade or bevel cutter	16
7.1.3 Fitting the saw blade and supplementary cutter	16
7.2 Setting the saw position 2	17
7.2.1 Fitting the saw blade	17
7.3 Adjusting the pipe dimensions	18
7.3.1 "Cutting" dimension setting (at saw positions 1 and 2)	18
7.3.2 "Beveling" dimension setting (only at saw position 1)	19
7.3.3 "Simultaneous cutting and beveling of thin-walled metal pipes $s = 1 - 2$ mm" dimension setting (only at saw position 1)	19
7.3.4 "Simultaneous cutting and beveling of metal pipes ( $s = 2 - 4.5$ mm)" dimension setting (only at saw position 1)	20
7.4 Selecting speed stages	21
7.5 Cutting the pipe (saw position 1 or 2)	22

---

7.6	Beveling the pipe (only at saw position 1)	24
7.6.1	Bevel correction (only at saw position 1)	26
7.7	Simultaneous cutting and beveling (only at saw position 1)	27
7.7.1	Simultaneous cutting and beveling of thin-walled pipes (s = 1 – 2 mm)	27
7.7.2	Simultaneous cutting and beveling of pipes (s = 2 – 4.5 mm)	28
7.7.3	Bevel correction (only at saw position 1)	29
8	Maintenance	30
8.1	Checking the level of the gear oil	32
8.2	Topping up gear oil	32
9	What to do if ...?	33
9.1	General trouble-shooting	33
9.2	Servicing/after-sales service	34

---

## 0 About these instructions

To allow quick understanding of these instructions and safe handling of the machine, all the warning messages, notes and symbols used in these instructions are presented here along with their meaning.

### 0.1 Warning messages

In these instructions, warning messages are used to warn you against the dangers of injury or material damage. Always read and observe these warning messages!



This is a warning symbol. It should warn you against dangers of injury.

Follow all instructions which are identified with this safety symbol in order to avoid injuries or death.

Warning symbol	Meaning
 <b>DANGER</b>	Direct danger! Non-observance could result in death or critical injury. ⊙ Restrictions (if applicable). ► Measures to prevent danger.
 <b>WARNING</b>	Possible danger! Non-observance could result in serious injury. ⊙ Restrictions (if applicable). ► Measures to prevent danger.
 <b>ATTENTION</b>	Dangerous situation! Non-observance could result in minor injuries.
<b>ATTENTION</b>	Dangerous situation! Non-observance could result in material damage.

## 0.2 Further symbols and displays

Symbol	Meaning
<b>Important Note</b>	Notes: Contain particularly important information for comprehension.
	Instruction: You must take notice of this symbol.
1.	Request for action in a sequence of actions: You have to do something here.
▶	Single request for action: You have to do something here.
▷	Conditional request for action: You have to do something here if the specified condition is met.

## 0.3 Abbreviations

Abbr.	Meaning
RA 41 Plus	Pipe Cutting and Beveling Machine, type RA 41 Plus
RA 41 Plus (H)	Pipe Cutting and Beveling Machine, type RA 41 Plus with intermediate gear

# 1 Notes on safety

The Pipe Cutting and Beveling Machine (referred to as RA 41 Plus (H) in the following) is a state-of-the-art machine. Using it for purposes other than those described in this manual may cause injury to the user or to others. It may also damage the machine or other equipment.

Therefore:

- Always ensure that the machine is in good working order and comply with these notes on safety.
- Keep complete documents close by the machine.
- Generally valid regulations for the prevention of accidents must be observed.

## 1.1 Proper use

- Only use the RA 41 Plus (H) for cutting and beveling of pipes.
- For damages caused by using not according to regulations is just the user responsible.

## 1.2 Safety regulations

- Only use the dimensions and materials specified in this manual. Always consult Orbitalum Tools after-sales service personnel before using other materials.
- Only use original Orbitalum Tools spare parts and auxiliaries.
- Inspect the RA 41 Plus (H) every day for visible signs of damage or defects. Any damage or defect must be repaired immediately.
- Work on the electrical installations may only be performed by a qualified electrician.
- Disconnect from the mains before changing the tools, maintenance- and repair-works and allow the machine to run a stop.
- Do not use the RA 41 Plus (H) unless all safety devices (restart inhibitor, overload protection and saw blade guard) are working properly and the fixtures are fitted securely on the baseplate or pipe-supply.

### 1.3 Working with safety in mind

"Make your contribution to safety in the workplace."



- Report any unusual behavior on the part of the machine to the person in charge immediately.
- Always work with safety in mind.
- Wear safety goggles, safety-gloves and hearing protection during working with the RA 41 Plus (H).
- Tie up long hair (snood-type cap); do not wear any wide clothes.  
**Attention:** jewels and ties can be grasped by the rotating parts.
- Switch the RA 41 Plus off after completing each stage of work and allow the machine to run a stop.
- Disconnect from the mains before cleaning-, maintenance- and repair-work the RA 41 Plus (H) and let the machine leak.
- Keep the RA 41 Plus (H) dry, do not use in the rain.
- Do not use the RA 41 Plus (H) in areas subject to explosion hazards.



**DANGER**

---

#### Danger of death by electric shock!

If the mains cable is damaged, live parts may cause death when being touched directly.

- ⊙ Keep the mains cable of the pipe cutter motor away from the saw blade or bevel cutter.
- ▶ Secure the falling pipe piece.
- ⊙ Do **not** let the cut-off pipe piece drop in an uncontrolled way.
- ⊙ Do **not** run the machine unattended.
- ▶ While processing the pipe, always keep an eye on the position of the mains cable.



**WARNING**

---

#### Danger of being injured by sharp cutting edges!

- ⊙ Keep hands away from the tools during cutting or beveling.
  - ⊙ **Never** equip both sawing positions with saw blade and bevel cutter at the same time.
  - ▶ Wear safety gloves.
-





---

### **Danger of being injured by the rotating slide housing!**

- ▶ Make sure that the slide housing starts from its home position.
  - ▶ Clamp the pipe to be processed into the vice.
  - ▶ Pull off the vice handle from the spindle before the slide housing starts rotating.
- 

## **1.4 Waste disposal / environmental protection**

- Dispose of chips and used gear lubricant oil according to the regulations.

**Discarded electric tools and accessories contain a large share of valuable raw and synthetic materials which can be recycled.**

**Therefore:**

- Electrical (electronic) devices which are marked with the symbol to the left, may not be disposed of with household waste in accordance to the EU directive 2002/96/EC.
- By actively using the offered return and collection systems, you actively contribute to the reuse, recycling and utilization of electrical (electronic) devices.
- Electrical (electronic) used devices contain parts which must be handled selectively according to the EU directive. Separate collection and selective treatment is the basis for environment-friendly disposal and the protection of human health.
- Our products that were sold to you after August 13th, 2005 are taken back and treated according to legal standards. These products have to be send free of charge.
- The return of used devices which pose a health or safety risk for human beings due to soiling during use may be refused.
- The legally compliant disposal of electrical (electronic) devices that were placed on the market before August 13th, 2005 are in the responsibility of the end-user.



(RL 2002/96/EC)

## **1.5 Further safety regulations**

Observe the regulations, standards and guidelines applicable in your country.

## 2 Design of the product

### 2.1 Standard

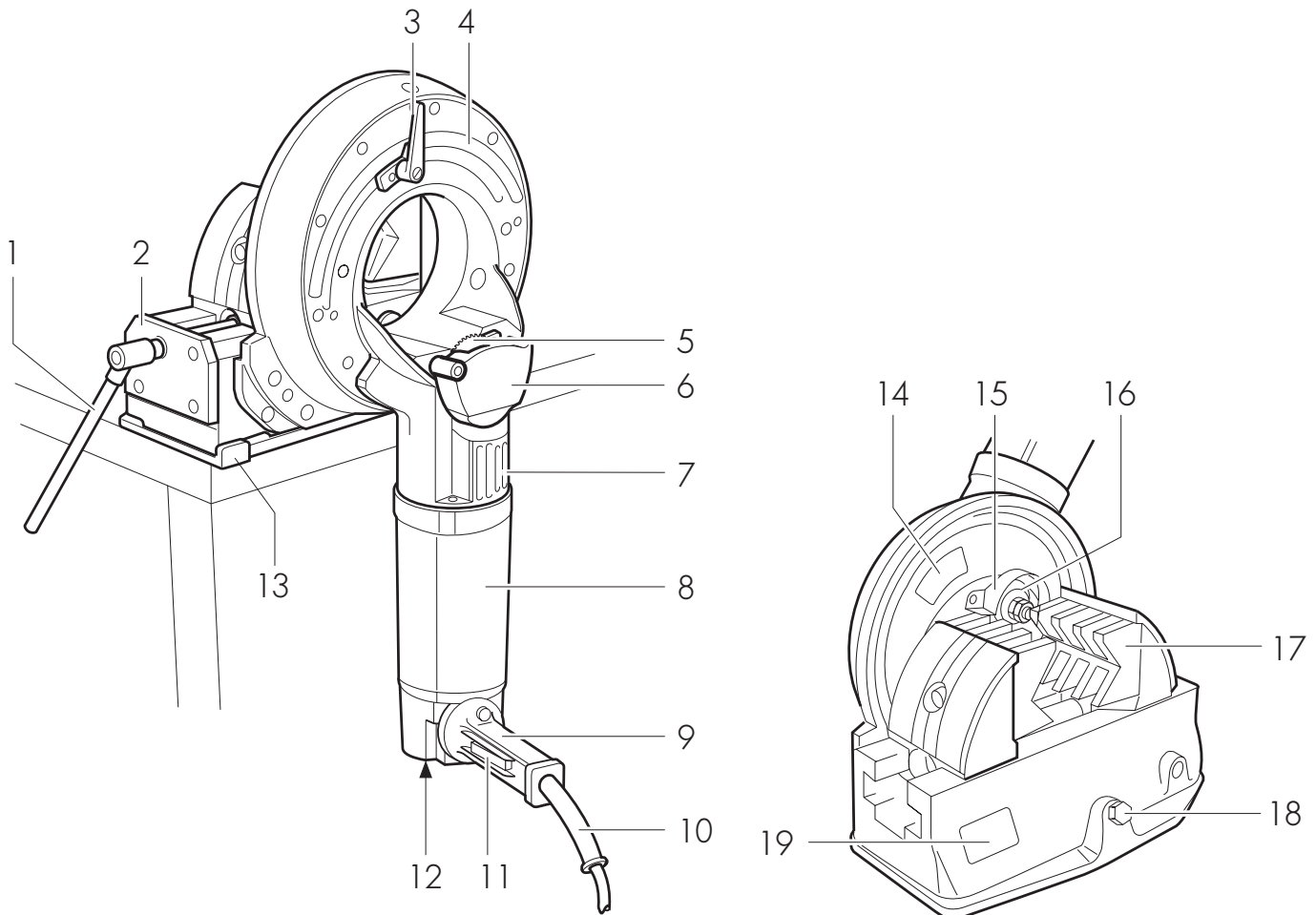

- |    |  |    |   |
|----|--|----|---|
| 1  | Vice handle                                  | 11 | On-off switch                               |
| 2  | Vice   | 12 | Speed setting                               |
| 3  | Clamping lever for pipe dimensioning         | 13 | Quick-mounting base plate                   |
| 4  | Dimension plate, to adjust the pipe diameter | 14 | Mounting plate                              |
| 5  | Saw blade position 2                         | 15 | Saw blade guard position 1                  |
| 6  | Saw blade guard position 2                   | 16 | Saw blade position 1                        |
| 7  | Rotary element                               | 17 | Aluminum clamping jaws                      |
| 8  | Electric motor                               | 18 | Fixing bolt RA to quick-mounting base plate |
| 9  | Motor grip                                   | 19 | Rating plate/machine number                 |
| 10 | Connecting lead with rotary contact          |    |   |

## 2.2 Accessories

Not contained in the scope of supply:

- Cast iron clamping jaws
- Aluminum clamping shells for deformation-free clamping of thin-walled metal tubes
- Intermediate gear (H) for cutting high-tech materials (nickel alloys, special stainless steel)

*Get further information from our current product catalogue.*

## 3 Features and scope of application

### 3.1 Features

The Pipe Cutting and Beveling Machine RA 41 Plus (H) is distinguished by the following main features:

- Increased safety due to stationary pipe and rotating tool.
- Self-centering vice.
- Low-maintenance gearing with oil-bath lubrication.
- Variable speed electric motor with restart inhibitor.
- Right-angled, burr-free, cold separating cut.
- Cold machining process.
- Quick cutting process.
- Easy and space-saving assembly.
- Fabrication of standardised welding bevels.
- Quick tool change.
- Simultaneous cutting and beveling of thin-walled metal pipes (only at saw position 1).
- Saw position 1: saw blade and clamping jaws are close to one another to absorb vibrations when sawing.
- Saw position 2: possibility of cutting elbows.

### 3.2 Scope of application

#### Working range\*

Material	Saw position	Pipe outer diameter OD [mm]	Pipe inner diameter ID [mm]	Wall thickness [mm]
Pipe	1	10 – 120	16 (saw blade-Ø 68 mm)	0.6 – 7
Elbow	2	30 – 120	4 (saw blade-Ø 80 mm)	

#### Pipe materials\*

Stainless steel with the following mass fractions:	Wall thickness [mm]
Cr ≤ 12%; Mo < 2%; Ni < 26%	1 – 7
Cr ≤ 20%; Mo = 0%; Ni < 13%	1 – 7
Cr ≤ 28%; Mo < 8%; Ni < 30%	1 – 2.5

- Unalloyed and low-alloyed steel
- High-alloyed steel  
(stainless steel, material no. 1.40... – 1.45... in accordance with DIN 17455 and 17456)
- Copper
- Brass
- Annealed cast-iron pipe (nodular graphite iron)
- Aluminum

\*) Consult Orbitalum Tools before using for other applications and/or materials.

## 4 Technical specifications

### 4.1 Rating

Dimensions	700 x 490 x 460 mm 27.6 x 19.3 x 18.1 inch
Weight	74 kg 163 lbs
Power	1600 W
Protection class	Totally insulated in accordance with class II, DIN VDE 0740
Speed RA 41 Plus	150 – 270 rpm
Speed RA 41 Plus (H) (incl. intermediate gear box)	40 – 70 rpm
Versions	1-phase AC 100 – 120 V, 50/60 Hz 200 – 240 V, 50/60 Hz
Vibration level in accordance with EN 28662, part 1	< 2.5 m/s <sup>2</sup>
Sound pressure level at workplace <sup>*)</sup>	at idle: approx. 76 dB (A) under load: approx. 85 dB (A)

As the noise level may also exceed 85 dB (A) under unfavorable operating conditions, we recommend the use of suitable ear protection when the machine is used for extended periods.

<sup>\*)</sup> The sound pressure level was measured under normal operating conditions in accordance with EN 23741.

## 5 Commissioning

### Checking the parts of delivery

- ▶ Check all parts of the delivery for completeness and transportation damage.
- ▶ Report any missing parts or transportation damage to your supplier immediately.

### 5.1 Included with the machine\*

- 1 Pipe Cutting and Beveling Machine RA 41 Plus (H)
- 1 Transportation box
- 1 Saw blade (Code 790 042 064)
- 1 Quick mounting plate
- 1 Tool set
- 1 Tube of saw blade lubricating compound GF TOP (Code 790 060 228)
- 1 Tube of special gear oil (Code 790 041 030)
- 1 Operating instructions with spare parts list

\*) Subject to modifications

## 6 Transport and assembly

### 6.1 Fitting the quick-mounting plate

Fit the pipe cutter together with the vice, either

- to the quick-mounting plate, or
- to the quick-mounting plate with screw clamps (special accessory).

1. Mark and punch the bolt holes on the work bench. Use the quick-mounting plate as a template.
2. Drill 13 mm Ø holes.
3. Fasten the quick-mounting plate with screws.

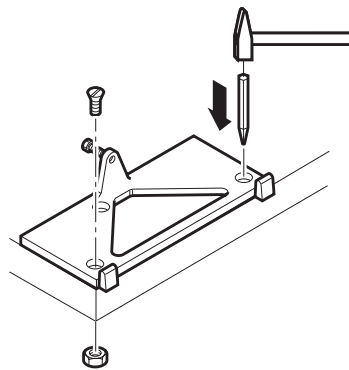

#### Pipe feeder base unit

Mount the pipe cutter directly and without further belongings on the mounting base plate (1) of the pipe feeder base unit (optional accessory, Code 790 068 051).

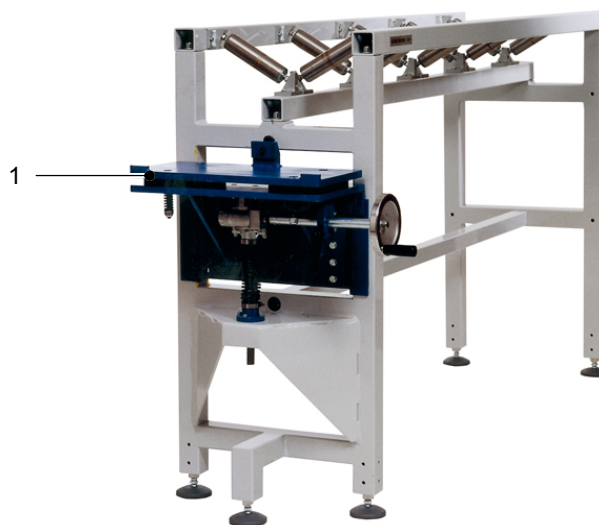



## 6.2 Transporting and fitting the pipe cutter



**DANGER**

---

### Danger of death caused by electric shock!

- ▶ Cut off the power supply before carrying out the transportation.
- 



**WARNING**

---

### Danger of being injured during transportation!

- ⊙ **Never** carry and fit the pipe cutter alone.
  - ▶ Transport and fit the pipe cutter with the aid of a crane or a similar lifting device.
- 

1. Clamp a suitable piece of tubing of an adequate length in the middle of the vice.
2. Position lifting belts around the piece of pipe on both sides of the vice.
3. Use the belts to lift the pipe cutter and slide onto the fitted quick-mounting base plate from the side.
4. Belt the pipe cutter down with the hexagon-head screw (1).

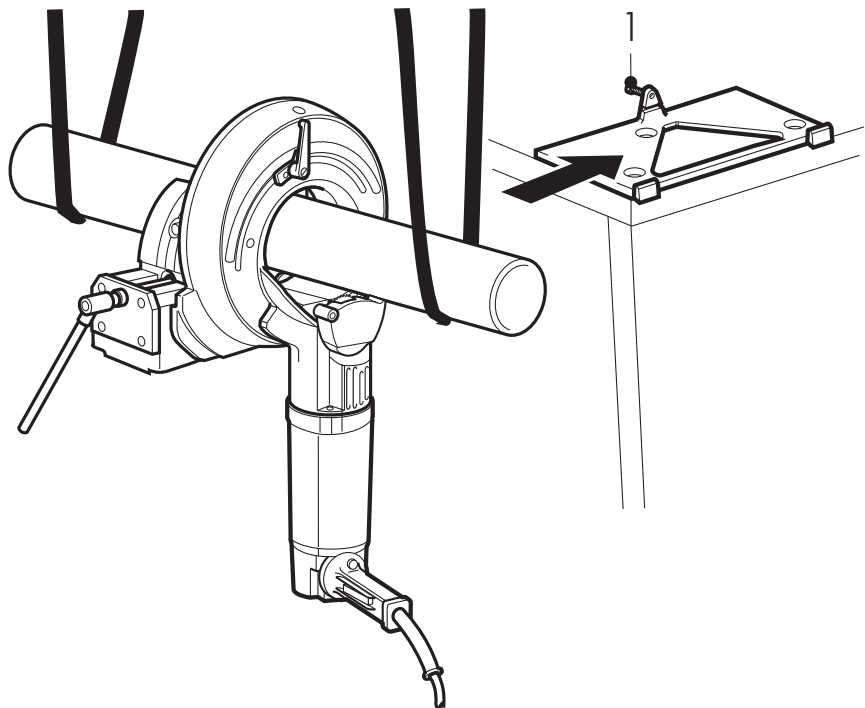

## 7 Operation

**Note** Use the RA 41 Plus (H) only for cutting and beveling of pipes. Please **absolutely consider** the possible ways of machining of the two sawing positions (see picture and table). For damages caused by using not according to regulations is just the user responsible.

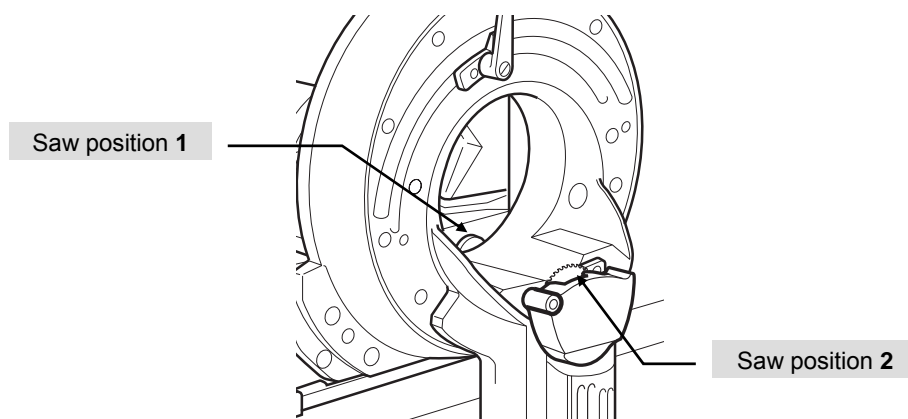

Saw position 1	Saw position 2
1. sawing	1. sawing
2. beveling	
3. sawing and beveling simultaneous	



**WARNING**



### Danger of being injured by sharp cutting edges or electric shock!

- ⊙ Keep hands away from the saw blade/bevel cutter when inserting or changing the tool.
- ⊙ **Never** equip both saw positions with saw blade/bevel cutter simultaneously!
- ▶ Wear safety gloves.
- ▶ Disconnect the mains plug before mounting or dismounting, maintenance or adjustment and allow the machine to run a stop.

## 7.1 Setting the saw position 1

### ATTENTION Damage to material

- ▶ The saw blade or bevel cutter must be free from chips and dirt.
- ▶ Only use Orbitalum Tools saw blades and cutters.
- ▶ When employing an additional cutter, only use the special Orbitalum Tools clamp washer, not the normal clamp washer.
- ▶ The inscription (1) on the saw blade (saw position 1) must always be facing towards the pipe cutter. Consider the assembly sign at the saw blade guard.

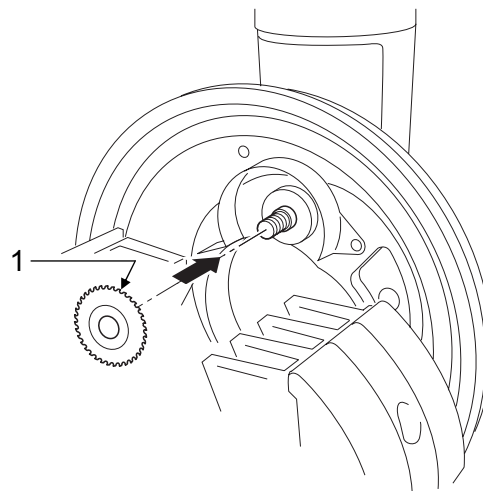

### 7.1.1 Preparatory work

1. Swivel the pipe cutter upwards by 180° in a clockwise direction.
2. Clean the saw blade shaft (1), the contact surface of the clamp (2) and vicinity.

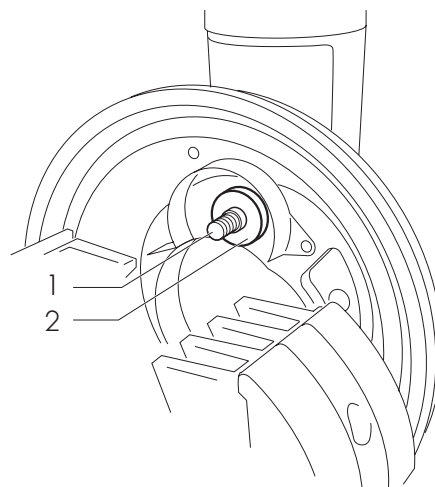

### 7.1.2 Fitting the saw blade or bevel cutter

1. Fit the following on to the shaft (1):
  - saw blade or bevel cutter (2)
  - clamping plate (3)
2. Tighten the nut (4) counter clockwise (left-hand thread).
3. Swivel the pipe cutter down into its starting position in a clockwise direction.

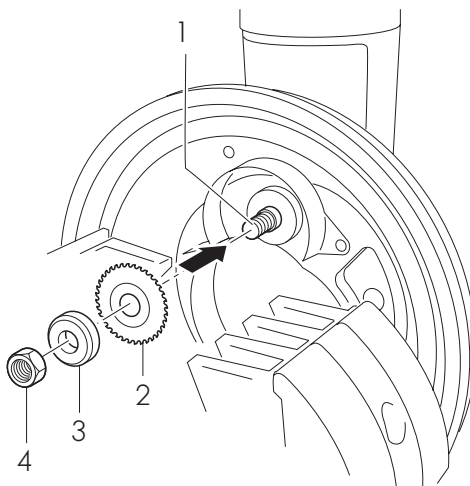

### 7.1.3 Fitting the saw blade and supplementary cutter

1. Fit the following on to the shaft (1):
  - saw blade (2), supplementary cutter (3) and clamping plate (4)
2. Tighten the nut (5) counter-clockwise (left-hand thread).
3. Swivel the pipe cutter down into the starting position in a clockwise direction.

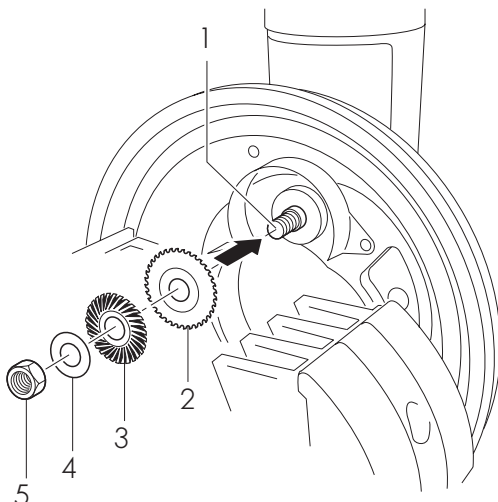

## 7.2 Setting the saw position 2

### ATTENTION Damage to material

- ▶ The saw blade must be free from chips and dirt.
- ▶ Only use Orbitalum Tools saw blades.
- ▶ Press the saw blade guard down by max. 90°.
- ▶ Mount the saw blade (saw position 2) with the inscription facing to you. The teeth will then be pointing to the correct direction.

### 7.2.1 Fitting the saw blade

1. Turn the saw blade guard (1) down for approx. 90°.
2. Loosen the hexagon nut (4). Remove the clamping plate (3) and the saw blade (2).
3. Clean the saw blade shaft and vicinity.
4. Fit the saw blade (2) and the clamping plate (3).
5. Tighten the hexagon nut (4).
6. Move the saw blade guard (1) back to its original position.

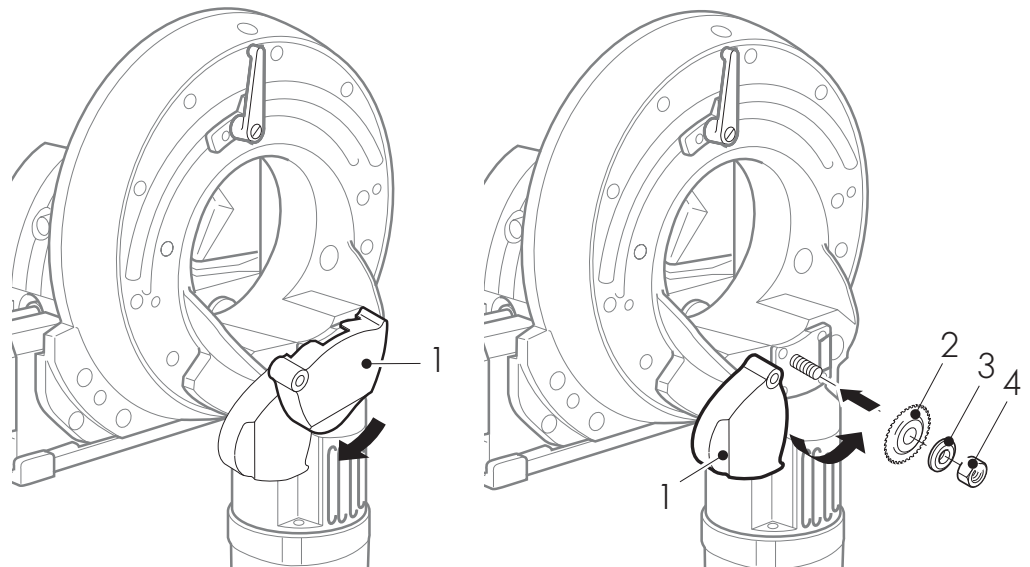

## 7.3 Adjusting the pipe dimensions

### 7.3.1 "Cutting" dimension setting (at saw positions 1 and 2)

**Note** Applies to standard saw blade OD = 68 mm only.

1. Measure the inner diameter ID of the pipe to be cut.
2. Release the clamping lever (1) and set the stop (2) to the required inner diameter ID on the upper scale, then tighten.
3. Insert the pipe until it is just in front of the saw blade.
4. Use the grip to swivel the motor upwards in a clockwise direction.

The saw blade must now project approx. 1.5 mm into the pipe.

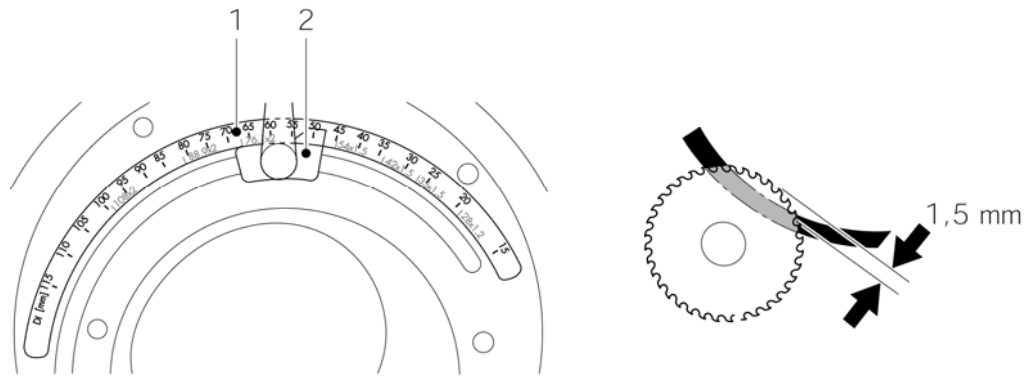

### 7.3.2 "Beveling" dimension setting (only at saw position 1)

**Note** Applies specifically to Orbitalum Tools profiling cutters to bevel the ends of pipes separately.

1. Insert the pipe into the vice.
2. Slide the pipe until it is just in front of the supplementary cutter and tighten in position.
3. Release the clamping lever.
4. Using the grip, swivel the motor upwards in a clockwise direction until the outer diameter of the cutter projects approx. 1 to 2 mm above the inner diameter of the pipe.
5. Tighten the clamping lever.

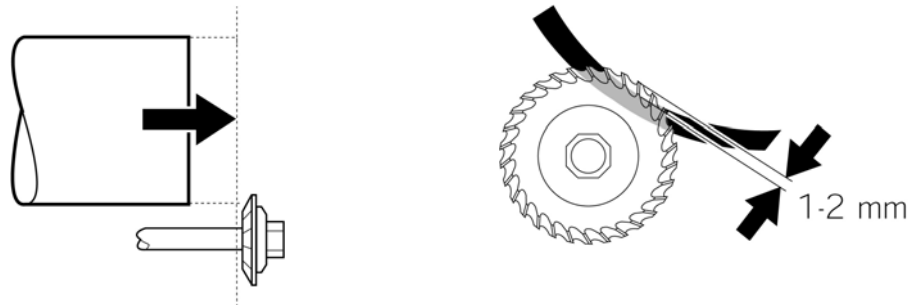

**Important** Setting ensures a minimum bevel height. See section 7.6.1, p. 26.

### 7.3.3 "Simultaneous cutting and beveling of thin-walled metal pipes $s = 1 - 2 \text{ mm}$ " dimension setting (only at saw position 1)

#### Only for Mannesmann-Pressfitting dimensions

- Note**
- ▶ Dimension setting only applies in conjunction with the Orbitalum Tools press fitting saw blade/cutter combination, Code 790 044 047.
  - ▶ Use Orbitalum Tools clamping shells ("Accessories", see section 2.2, p. 7).

1. Measure the outer diameter OD (mm) of the pipe to be cut.
2. Release the clamping lever (1).
3. Set the stop (2) to the outer diameter OD x s (lower scale).
4. Tighten the clamping lever (1).

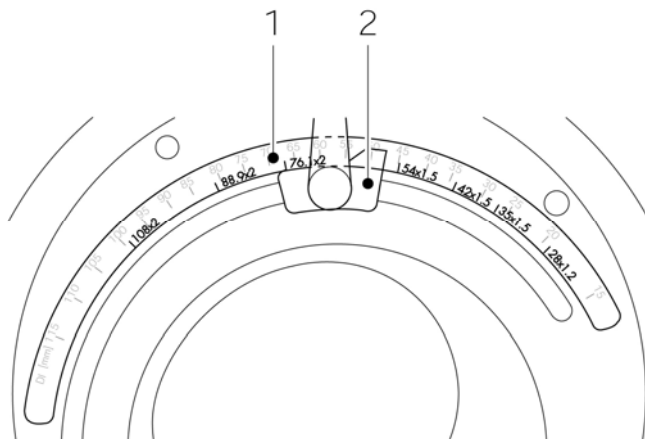

#### 7.3.4 "Simultaneous cutting and beveling of metal pipes (s = 2 – 4.5 mm)" dimension setting (only at saw position 1)

**Note** Dimension setting only applies to Orbitalum Tools supplementary cutters for the simultaneous beveling and cutting of metal pipes.

1. Place the pipe in the vice and slide it until it is just in front of the bevel cutter, then tighten.
2. Release the clamping lever.
3. Using the grip, swivel the motor in a clockwise direction until the saw blade projects approx. 1.5 mm into the pipe.
4. Tighten the clamping lever.

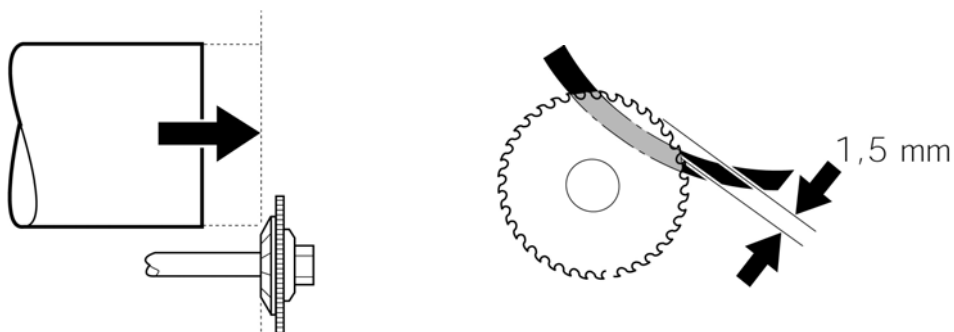

**Note** Setting ensures a minimum bevel height. If the bevel is too small, see section 7.7.3, p. 29.



## 7.4 Selecting speed stages

Type	Pipe material	Controller setting (1)	Spindle-speed (rpm)
RA 41 Plus	Stainless steel (material no. 1.40...-1.45...) with wall thickness of between 1 mm and max. 3 mm	1 – 3	150 – 190
	Low-alloy steel	2 – 4	175 – 200
	Unalloyed steel, copper, brass, aluminum, plastic, annealed cast-iron pipe	4 – 6	220 – 270
RA 41 Plus (H)*	Stainless steel (high grade)	1 – 6	40 – 70
	High-tech material (nickel chrome molybdenum alloy)	1 – 3	40 – 55

\* (H) = with intermediate gear

**Important** Select low speed:

- for large-diameter pipes
- for thick-walled pipes
- when a supplementary cutter is used

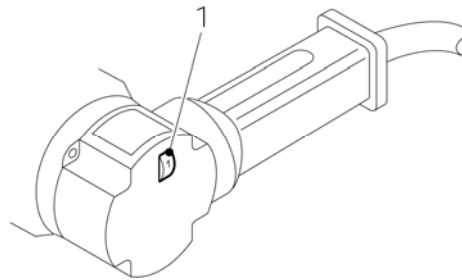

## 7.5 Cutting the pipe (saw position 1 or 2)



### Danger of being injured by chips flying around!

- ⊘ **Never** work without the saw blade guard mounted.
- ▶ Wear protective goggles.

### Danger of being injured by sharp cutting edges or electric shock!

- ⊘ Keep hands away from the tools during cutting.
- ⊘ **Never** equip both saw positions with saw blade/bevel cutter simultaneously
- ▶ Wear safety gloves.
- ▶ Disconnect the mains plug before mounting or dismounting, maintenance or adjustment and allow the machine to run a stop.

### Important

If the pipe cutter has not been used for a long time:

- Turn the motor by 180°.
- Switch the motor on and let it run for approx. 10 s.

This will ensure that all gear components are lubricated.

1. Set the pipe dimension (see section 7.3.1, p. 18).
2. Mark the cutting point on the pipe.
3. Tighten the hexagon nut securing the saw blade (see section 7.1, p. 15).
4. Slide the pipe through the vice to the desired length and clamp tight.
5. Use the pipe support (Code 790 052 301) or the pipe feeder (Code 790 068 001) for pipes that are more than 1m long.

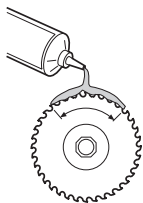
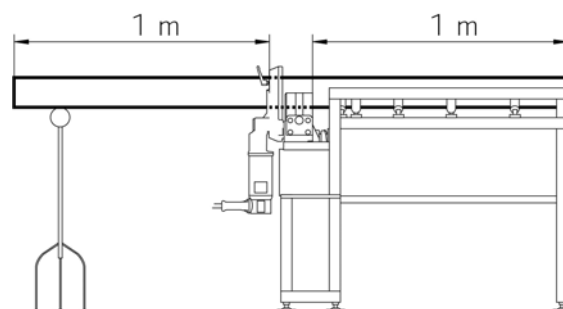

6. Apply saw blade lubricant to the saw blade:

- after every three cutting operations for pipes with outside diameters up to 60 mm,
- after each cutting operation for pipes with outside diameters more than 60 mm,
- after every cutting operation for chrome-plated and alloyed steel pipes

**Important** Use Orbitalum Tools lubricating gel only for pipes which come into contact with drinking water or foodstuffs.

**Important** Pull off the vice handle from the spindle before the slide housing starts rotating.

7. Connect the RA 41 Plus (H) to the mains.
8. Switch the motor on.
9. Using the grip (1), turn motor carefully in a clockwise direction until the wall of the pipe has been pierced.

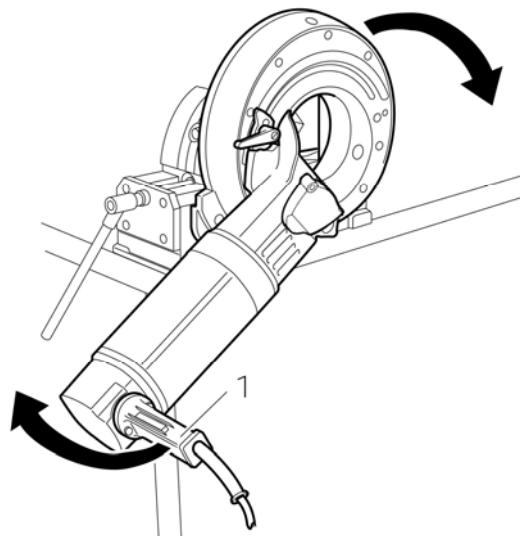

10. Continue turning smoothly until the pipe has been cut off and the marks (2) on the rotary element and housing are in line.

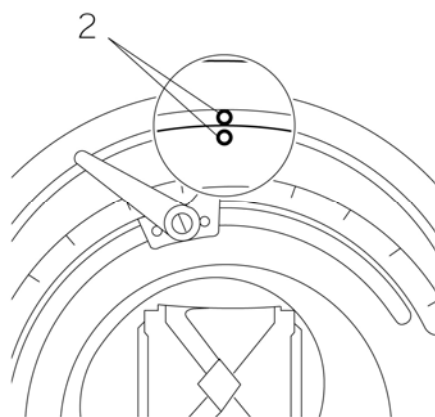

11. Turn the pipe cutter counter-clockwise until it is back in its home position.
12. Switch the motor off.

**For continuous operation**

After cutting, loosen the hexagon nut on the saw blade to prevent damage caused by tension.

## 7.6 Beveling the pipe (only at saw position 1)



**WARNING**

### Danger of being injured by chips flying around!

- ⊘ **Never** work without the saw blade guard mounted.
- ▶ Wear protective goggles.

### Danger of being injured by sharp cutting edges or electric shock!

- ⊘ Keep hands away from the tools during beveling.
- ⊘ **Never** equip both saw positions with saw blade/bevel cutter simultaneously
- ▶ Wear safety gloves.
- ▶ Disconnect the mains plug before mounting or dismounting, maintenance or adjustment and allow the machine to run a stop.

### Important

If the pipe cutter has not been used for a long time:

- Turn the motor by 180°.
- Switch the motor on and let it run for approx. 10 s.

This will ensure that all gear components are lubricated.

1. Adjust the bevel cutter (see section 7.3.2, p. 19).
2. Tighten the hexagon nut securing the saw blade if necessary (see section 7.3.2, p. 19).

### Important

The pipe must not project beyond the cutter during the beveling operation, always clamp into position 1 mm in front of the cutter.

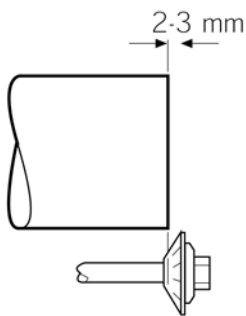

3. Slide the pipe through the vice until it is 2 to 3 mm in front of the bevel cutter, then clamp tight.
4. Use the pipe support (Code 790 052 301) or the pipe feeder (Code 790 068 001) for pipes that are more than 1 m long.

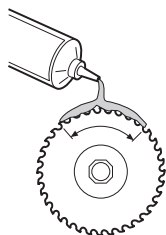
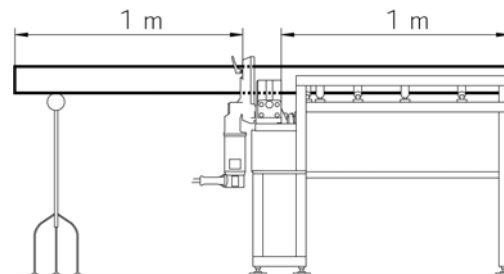

5. Apply saw blade lubricant to the bevel cutter.

- Important** Use Orbitalum Tools lubricating gel only for pipes which come into contact with drinking water or foodstuffs.
- Important** Pull of the vice handle from the spindle before the slide housing starts rotating.
6. Connect the RA 41 Plus (H) to the mains.
  7. Switch the motor on.
  8. Using the grip (1), turn the motor carefully in a clockwise direction until the bevel cutter engages.

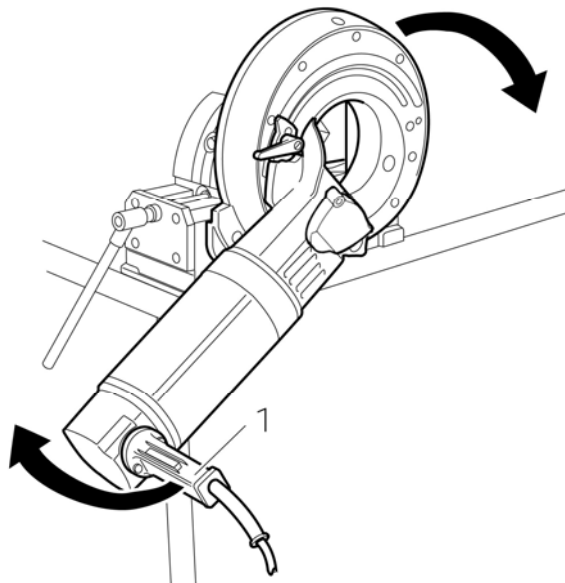

9. Continue to turn smoothly until the pipe has been beveled and the markings (2) on the rotary element and housing are in line.

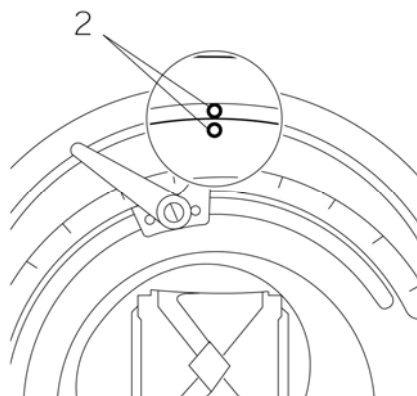

10. Switch the motor off.

**For continuous operation**

After cutting, loosen the hexagon nut on the saw blade to prevent damage caused by tension.

### 7.6.1 Bevel correction (only at saw position 1)

The size of the bevel can be increased by:

**Advancing the cutter:** If the bevel of the cutter is wide enough.

- ▶ The cutter moves further into the pipe wall and the bevel is larger.

  1. Release the clamping lever (1).
  2. Move the stop (2) to the right.
  3. Switch the motor on.
  4. Using the grip, turn the motor carefully in a clockwise direction until the bevel cutter engages.
  5. Continue to turn smoothly until the pipe has been beveled and the markings on the rotary element and housing are in line.
  6. Switch the motor off.

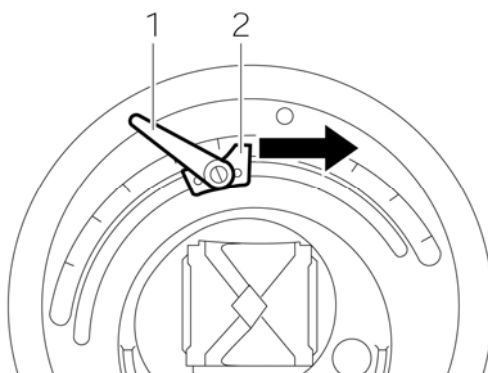

**Sliding the tube further into the vice:**

If the cutter does not have a very wide bevel.

- ▶ The bevel will be larger for the same setting.

## 7.7 Simultaneous cutting and beveling (only at saw position 1)

At saw position 1 pipes with wall thickness up to 4.5 mm can be cut and beveled at the same time.

### Important

If supplementary cutter is used, turn the motor around the pipe more slowly than you would during a normal cutting operation as two tools are being used at the same time.



**WARNING**

---

### Danger of being injured by chips flying around!

- ⊙ **Never** work without the saw blade guard mounted.
- ▶ Wear protective goggles.

### Danger of being injured by sharp cutting edges or electric shock!

- ⊙ Keep hands away from the tools during sawing/beveling.
  - ⊙ **Never** equip both saw positions with saw blade/bevel cutter simultaneously
  - ▶ Wear safety gloves.
  - ▶ Disconnect the mains plug before mounting or dismounting, maintenance or adjustment and allow the machine to run a stop.
- 

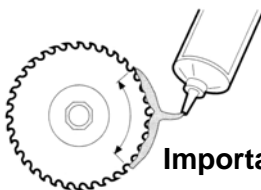

**Important**

1. Connect the RA 41 Plus (H) to the mains.
2. Apply saw blade lubricant to the teeth of the saw blade and cutting surfaces.

Relubricate after every cutting operation. Use Orbitalum Tools lubricating gel only for pipes which come into contact with drinking water or foodstuffs.

### 7.7.1 Simultaneous cutting and beveling of thin-walled pipes (s = 1 – 2 mm)

1. Set the pipe dimension as described in section 7.3.3, p. 19.
2. Mark the cutting point on the pipe.
3. Insert the pipe into the vice.
4. Slide the marked cutting point over the saw blade.
5. Clamp the pipe in the vice.
6. Use the pipe support (Code 790 052 301) or the pipe feeder (Code 790 068 001) for pipes that are more than 1 m long.

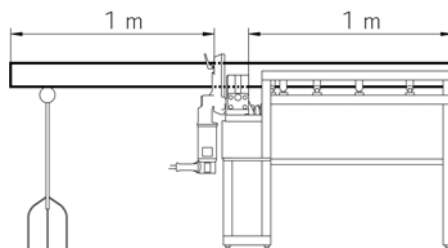

7. Switch the motor on.
8. Using the grip (1) turn the motor carefully in a clockwise direction until the wall of the pipe has been pierced.

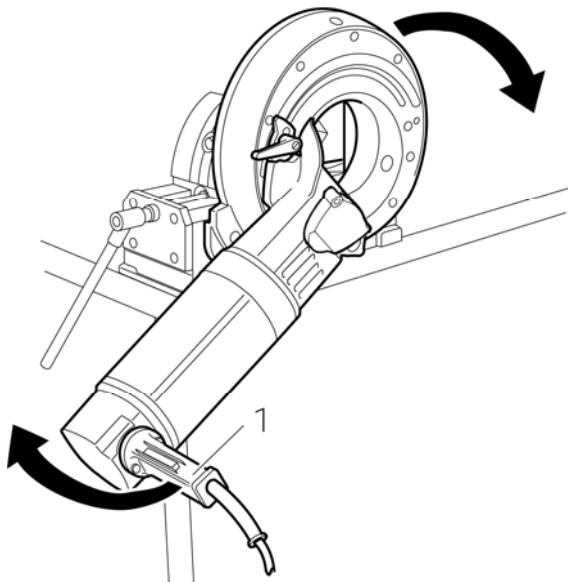

9. Continue to turn smoothly until the tube has been cut and the markings (2) on the rotary element and housing are in line.

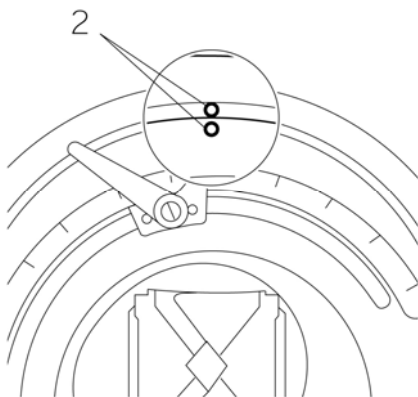

10. Turn the pipe cutter back to its home position.
11. Switch the motor off.

**For continuous operation**

After cutting, loosen the hexagon nut on the saw blade to prevent damage caused by tension.

**7.7.2 Simultaneous cutting and beveling of pipes (s = 2 – 4.5 mm)**

1. Set the pipe dimension as described in section 7.3.4, p. 20.
2. Proceed according to the steps described in section 7.7.1, p. 27.



### 7.7.3 Bevel correction (only at saw position 1)

If a bevel is too small, it can be corrected by advancing the cutter:

1. Release the clamping lever (1).
2. Move the stop (2) to the right.
3. Switch the motor on.
4. Using the grip, turn the motor carefully in a clockwise direction until the bevel cutter engages.
5. Continue to turn smoothly until the pipe has been beveled and the markings on the rotary element and housing are in line.
6. Switch the motor off.

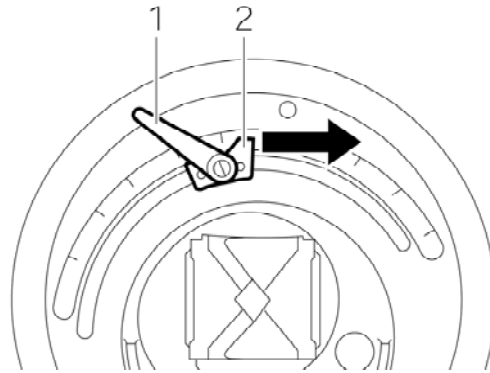

*The cutter moves further into the pipe wall and the bevel becomes larger.*

## 8 Maintenance

The Pipe Cutting and Beveling Machine RA 41 Plus (H) is designed for a long service life and low maintenance.

Please follow the maintenance instructions below.



**DANGER**

### **Danger of death by electric shock!**

- ▶ Pull the mains plug before carrying out any maintenance work and allow the machine to run a stop.

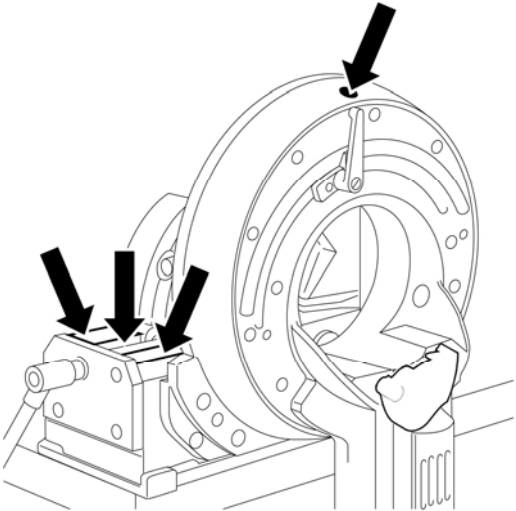
Interval	Activity
Before starting work.	<ul style="list-style-type: none"> <li>▶ Remove any chips and dirt from the saw blades.</li> <li>▶ Keep vent holes free from chips.</li> </ul>
Every week.	<ul style="list-style-type: none"> <li>▶ Remove the saw blade and use the brush to clean off any chips.</li> <li>▶ Oil the 4 points marked with arrows.</li> <li>▶ Check the oil level in the gear through the oil level viewglass and top up with gear oil if necessary (see "Topping up gear oil").</li> </ul> 
After the first 150 operating hours (after 3 months at the latest), then every 1000 operating hours (every year).	<ul style="list-style-type: none"> <li>▶ Check the oil level in the gear through the oil level viewglass and top up with gear oil if necessary (see "Topping up gear oil", section 8.2, p. 32).</li> </ul>

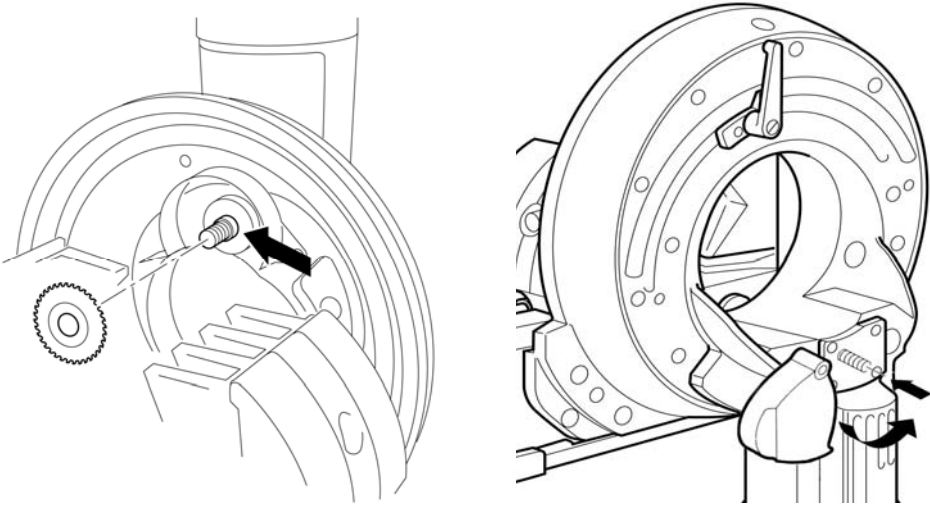
Interval	Activity
<p>Every time the cutter is cleaned.</p> <p>Every tool change.</p>	<p>▶ Do not use compressed air to clean the area at the end of the shaft marked with an arrow as the rotary shaft seal may otherwise be damaged by chips.</p> <p>Use a cloth or brush to clean the end of the shaft.</p> 

## 8.1 Checking the level of the gear oil

- ▶ Using the grip, turn the motor counter-clockwise from its home position by approx. 120° until the marking (3) on the rotary element is in line with the notch on the housing (approx. 8 o'clock position).

The oil level should be visible in the middle of the oil level viewglass (1).

## 8.2 Topping up gear oil

- ▶ Check the oil level through the oil-level viewglass as described above and top up with oil if necessary.

- Topping up:**
1. Undo the oil filler plug (2).
  2. Fill with special Orbitalum Tools gear oil.
  3. Keeping the motor in this position, check the oil level. Continue to top up with oil until the oil level is visible in the middle of the oil level viewglass.

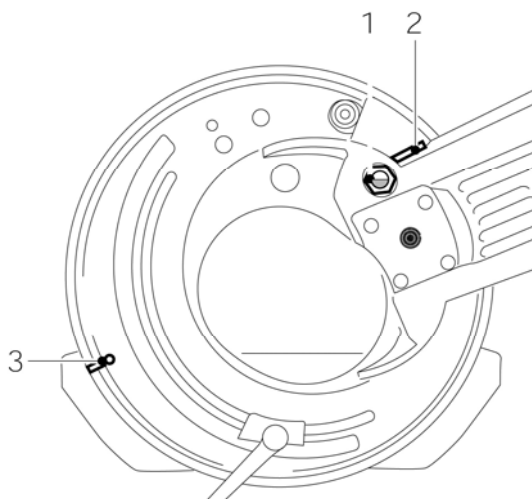

## 9 What to do if ...?

### 9.1 General trouble-shooting

In the following table you will find possible causes of faults and the appropriate remedies.

Problem	Possible cause	Remedy
Motor not running.	The overload protection relay has tripped.	▶ Turn switch to "0", wait approx. 15 min and switch the pipe cutter on.
	The restart inhibitor has tripped.	▶ Turn switch to "0", then switch the pipe cutter on.
The pipe cutter will not turn.	Pipe dimension not set correctly.	▶ Set the correct pipe dimension (see section 7.3, p. 18).
The saw blade will not cut and is slipping.	Hexagon nut on saw blade shaft not tightened.	▶ Tighten the hexagon nut.
The saw blade will not cut.	Saw blade mounted the wrong way round.	▶ Fit the saw blade correct (see section 7.1, p. 15 and section 7.2, p. 17).
The pipe is not beveled concentrically.	Pipe ( $\geq 1$ mm) not clamped properly.	▶ Use pipe support or pipe feeder.
	Thin-walled pipe clamped too tightly.	▶ Release the tension slightly or use clamping shells (see section 2.2, p. 7).
The pipe is not cut properly.	Pipe dimension not set correctly.	▶ Set the correct pipe dimension (see section 7.3, p. 18).
	Clamping lever not tightened.	▶ Tighten the clamping lever.
Poor machine quality on cut and beveled surfaces.	Tool is blunt.	▶ Use new original Orbitalum Tools tool.
	Inadequate tool lubrication.	▶ Lubricate saw blade and/or cutter.
	Wrong speed setting.	▶ Set the speed in accordance with the table in section 7.4, p. 21.

## 9.2 Servicing/after-sales service

For ordering spare parts, see the separate spare parts list. For troubleshooting, please contact your competent branch office directly.

Please state the following details:

- Machine type: **RA 41 Plus (H)**
- Machine number: *(see identification plate)*



**Orbitalum Tools GmbH**  
Josef-Schüttler-Straße 17  
78224 Singen, Deutschland  
Tel. +49 (0) 77 31 / 792-0  
Fax +49 (0) 77 31 / 792-524  
tools@orbitalum.com  
www.orbitalum.com

An ITW Company

790 046 773\_04/04 (07.08)  
© Orbitalum Tools GmbH  
D-78224 Singen 2008  
Printed in Germany